

# SMM03QC

**Required Tools:**  
M4 Allen wrench  
Phillips Screwdriver

**Contents:**

#	QTY	Name
1	1	Multiple Monitor Bracket
2	2	Handle Cap
3	4	Handle Claw
4	1	Handle

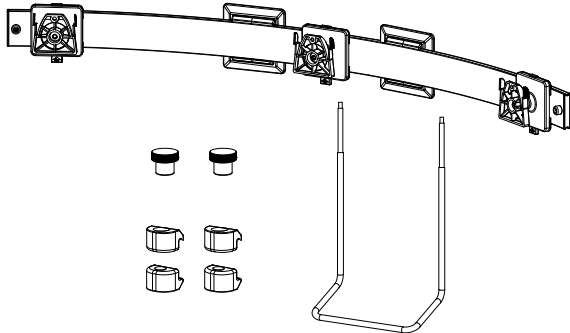

US Patent: 6,695,270 B1 6,758,454 B2 7,316,377 B2



Slide mount  
onto rail with  
tab in up  
position

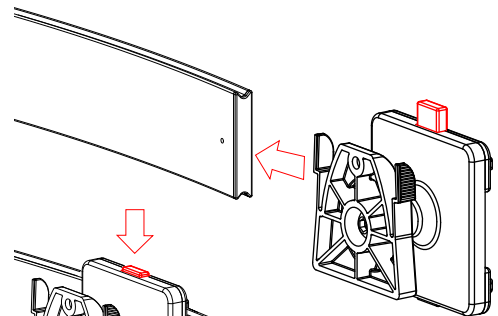

Push tab down  
to lock in place

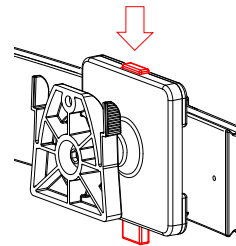

Apply screw  
and rubber  
stop.

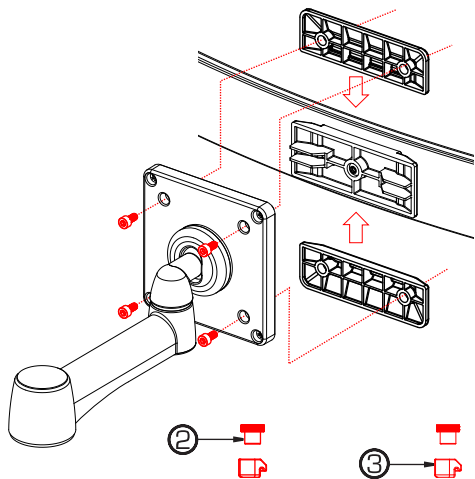
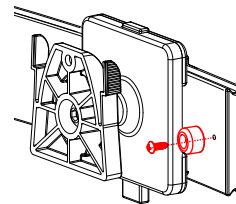

**To secure the handle:**

Slide handle claws  
down handle with  
claws facing the  
rail lip. Once handle  
claws are in place  
tighten down handle  
caps.

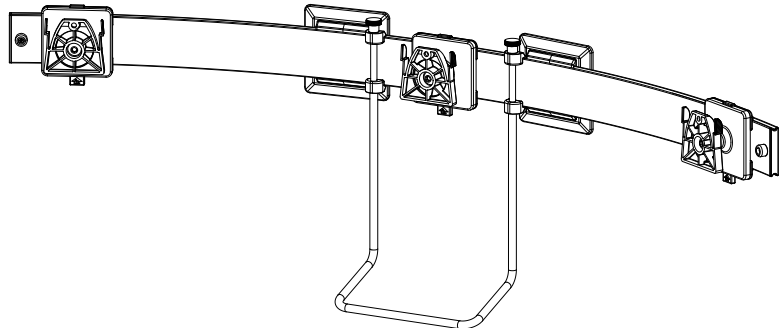
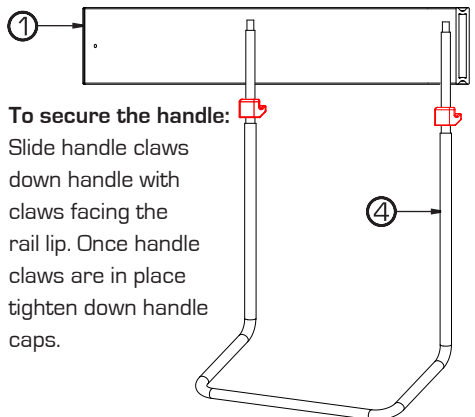

DISCLAIMER OF DAMAGES FOR IMPROPER USE. SpaceCo shall not be responsible for damage to its products, or injuries or damages caused by its products, resulting from improper installation, maintenance, unintended use or attempts to operate such products beyond their mechanical capacity, intentionally or otherwise, or by reason of unauthorized repair.

**SpaceCo Business Solutions, Inc.**  
800.840.8499  
www.spaceco.com