

# SPACEARM MULTI-MONITOR RAIL SOLUTIONS

- Mount dual monitors on a single SpaceArm or multiple monitors on a double SpaceArm using our rail solutions.

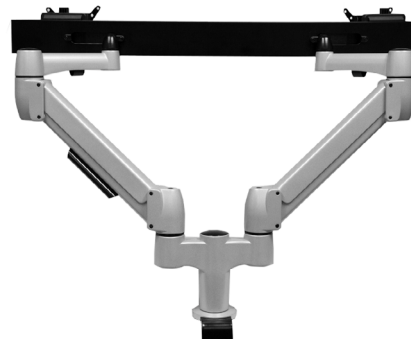

Single Arm Dual Monitor SpaceArm  
SMM02SA01



Dual Monitor Dual Arm SpaceArm  
SMM22SA02

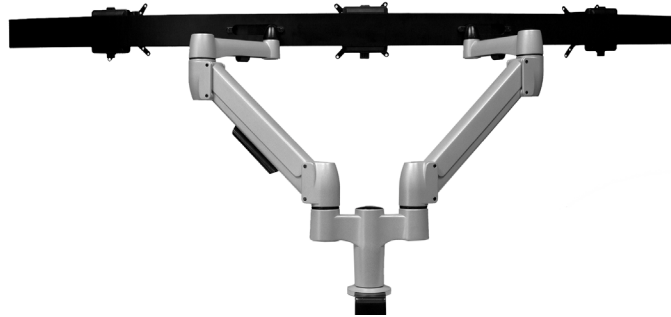

Three Monitor Dual Arm SpaceArm  
SMM03SA02

*All arms above are shown with optional Quick Change (QC) mount plate.*

## Environmental Design Attributes

### SpaceArm:

- Recycled content of aluminum - 100%
- Recyclable aluminum after use - 100%

### Cardboard Packaging:

- Recycled content - 20%
- Recyclable after use - 100%

### Pulp Tray:

- Recycled content - 100%
- Recyclable after use - 100%

### Plastic Packaging:

- Low density polyethylene
- Recycled content - 30%
- Recyclable after use - 100%

## Benefits

- Security - Keep your monitors and tablets safe with anti-theft features.
- Positioning - Easy access and alignment for multiple monitor or tablet applications.
- Organization - Easy access and alignment for multiple monitors.
- Ergonomic - A wide range of adjustments puts your monitor in the most comfortable position for you.
- Space - Increases work surface efficiencies by positioning the monitor on an arm.
- Technology - Flexible and adaptable for inevitable upgrades.
- Environment - Reusable and sustainable product design.

# SPACEARM MULTI-MONITOR RAIL SOLUTIONS

## Single Arm Dual Monitor SpaceArm SMM02SA01

Length of extrusion:  
Fits 2; 24" 609.6mm  
widescreen monitors

Available weight ranges:  
2-10lbs. 5-16lbs. or 15-30lbs.  
0.9-4.5kg 2.67-7.25kg or 7-14kg

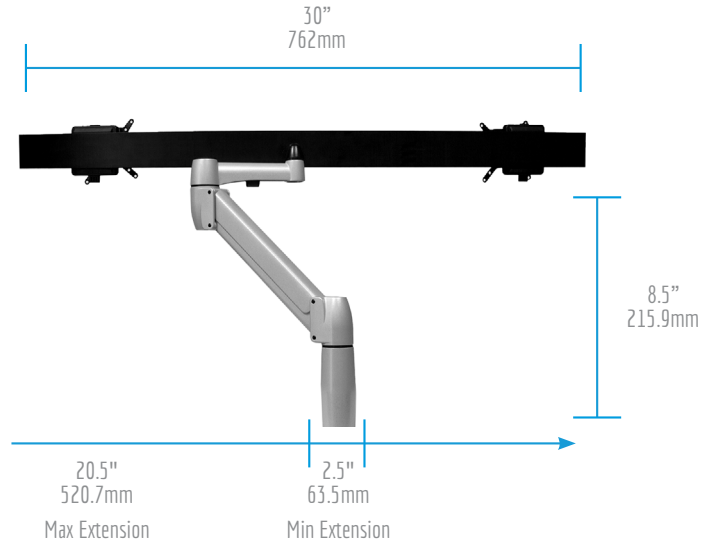

## Dual Monitor Dual Arm SpaceArm SMM22SA02

Length of extrusion:  
Fits 2; 24" 609.6mm  
widescreen monitors

Available weight ranges:  
2-10lbs. 5-16lbs. or 15-30lbs.  
0.9-4.5kg 2.67-7.25kg or 7-14kg

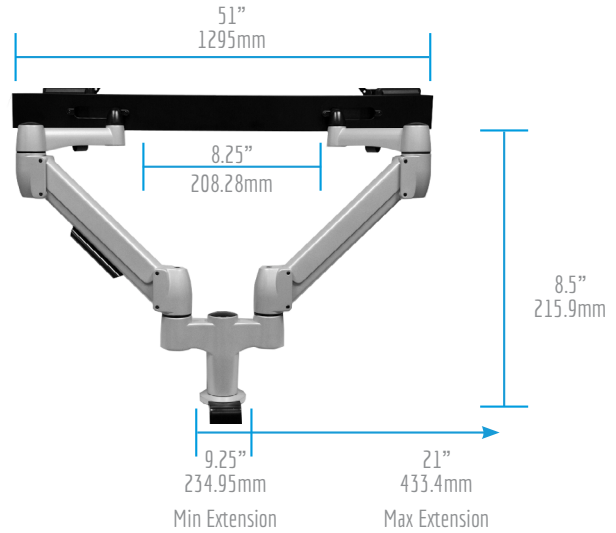

## Three Monitor Dual Arm SpaceArm SMM03SA02

Length of extrusion:  
Fits 2; 24" 609.6mm  
widescreen monitors

Available weight ranges:  
2-10lbs. 5-16lbs. or 15-30lbs.  
0.9-4.5kg 2.67-7.25kg or 7-14kg

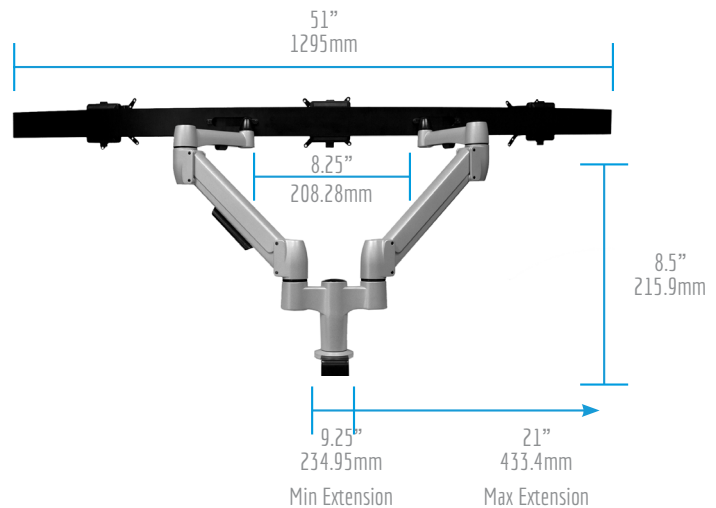

## MOUNTING OPTIONS



**Bolt Through**  
*BT*

We also carry a number of vertical mounts from manufacturers such as Steelcase, Allsteel, Haworth, Teknion, Knoll, Herman Miller, DIRTT and others. To learn more, please visit our website.

## COLOR OPTIONS

**Platinum**  
*PLT*



**Black**  
*BLK*



**White**  
*WHT*



**Champagne**  
*CHA*



## Technical Specs

- Thermo-fused polyester finish
- High pressure die-cast aluminum construction
- 5-axis position adjustment
- Conforms to VESA 75mm x 75mm, 100mm x 100mm and 100mm x 200mm mounting patterns
- 40 degrees of tilt (20 degrees+/20 degrees-)
- 360 degree monitor rotation
- 360 degree arm rotation
- 2.5" (63.5mm) depth in the folded position
- 4" (355.6mm) of travel (7" (177.8mm) above the center of hub and 7" (177.80mm) - below the center of hub)
- Gas spring standard 5-16lbs (2.67kg - 7.25kg)
- Gas spring options, 2-10lbs (.90kg - 4.53kg) and 15-32lbs (6.8kg - 14.51kg)
- Quick Change Mount and Direct Mount for monitor application
- Mounts available: Bolt through, C-Clamp, Large C-Clamp, Grommet, Single Resolve, Double Resolve, Race, Wall, Column, SpaceBeam 1, SpaceBeam 2, Adjustable Slatwalls